



## IECEX OPERATIONAL DOCUMENT

**IEC System for Certification to Standards Relating to Equipment for Use in Explosive Atmospheres (IECEX System)**

**IECEX Certified Service Facilities Scheme –  
Part 5: Repair, overhaul and reclamation of Ex equipment**

**Additional requirements for IECEX Service Facilities involved  
in the repair, overhaul and reclamation of Ex equipment**



## THIS PUBLICATION IS COPYRIGHT PROTECTED

Copyright © 2023<sup>4</sup> IEC, Geneva, Switzerland

All rights reserved. Unless otherwise specified, no part of this publication may be reproduced or utilized in any form or by any means, electronic or mechanical, including photocopying and microfilm, without permission in writing from either IEC or IEC's member National Committee in the country of the requester. If you have any questions about IEC copyright or have an enquiry about obtaining additional rights to this publication, please contact the address below or your local IEC member National Committee for further information..

IEC Central Office  
3, rue de Varembé  
CH-1211 Geneva 20  
Switzerland

Tel: +41 22 919 02 11  
[info@iec.ch](mailto:info@iec.ch)  
[www.iec.ch](http://www.iec.ch)

### About the IEC

The International Electrotechnical Commission (IEC) is the leading global organization that prepares and publishes International Standards for all electrical, electronic and related technologies.

### About IEC publications

The technical content of IEC publications is kept under constant review by the IEC. Please make sure that you have the latest edition, a corrigendum or an amendment might have been published.

#### IEC publications search - [webstore.iec.ch/advsearchform](http://webstore.iec.ch/advsearchform)

The advanced search enables to find IEC publications by a variety of criteria (reference number, text, technical committee, ...). It also gives information on projects, replaced and withdrawn publications.

#### IEC online collection - [oc.iec.ch](http://oc.iec.ch)

Discover our powerful search engine and read freely all the publications previews. With a subscription you will always have access to up to date content tailored to your needs.

#### IEC Just Published - [webstore.iec.ch/justpublished](http://webstore.iec.ch/justpublished)

Stay up to date on all new IEC publications. Just Published details all new publications released. Available online and once a month by email.

#### Electropedia - [www.electropedia.org](http://www.electropedia.org)

The world's leading online dictionary on electrotechnology, containing more than 22 000 terminological entries in English and French, with equivalent terms in 18 additional languages. Also known as the International Electrotechnical Vocabulary (IEV) online.

#### IEC Customer Service Centre - [webstore.iec.ch/csc](http://webstore.iec.ch/csc)

If you wish to give us your feedback on this publication or need further assistance, please contact the Customer Service Centre: [sales@iec.ch](mailto:sales@iec.ch).

Readline



# IECEX OPERATIONAL DOCUMENT

**IEC System for Certification to Standards Relating to Equipment for Use in Explosive Atmospheres (IECEX System)**

---

**IECEX Certified Service Facilities Scheme –  
Part 5: Repair, overhaul and reclamation of Ex equipment**

**Additional requirements for IECEx Service Facilities involved  
in the repair, overhaul and reclamation of Ex equipment**

INTERNATIONAL  
ELECTROTECHNICAL  
COMMISSION

---

Readline Version

## CONTENTS

CONTENTS .....	2
FOREWORD.....	3
INTRODUCTION.....	4
1. Scope.....	5
2. Normative references .....	5
3. Definitions and terms .....	5
4. Additional requirements associated with efficiency to maintain T Ratings of rotating machines .....	5
5. Additional requirements: Protection "d" – Flameproof enclosures.....	5
5.1 Machining limits for flameproof surfaces .....	5
5.2 Over-pressure test .....	6
6. Additional requirements for rotating electric machines .....	6
7. Knowledge, skills and competencies of Responsible Persons and Operatives in accordance with IEC 60079-19 Annex B.....	6
Annex A (informative) Additional information on over-pressure test procedure and machining limits.....	7
A.1 Over-pressure test procedure .....	7
A.1.1 Introduction.....	7
A.1.2 Test procedure.....	7
A.1.3 Reporting of results.....	8
A.1.4 Interpretation of results .....	8
A.2 Machining limits .....	9
Annex B (informative) Additional information for compliance with IEC60034-23 .....	2
B.1 General.....	2
B.2 Specific requirements.....	2
C.1 Service Facility Equipment .....	5
Annex C (informative) Recommended report form.....	7
C.1 Report for motors – Type of protection "d" (Flameproof).....	8
C.2 Report for enclosures – Type of protection type "d" (Flameproof) .....	9
C.3 Report for equipment installed within enclosures – Type of protection type "d" (Flameproof).....	10
C.4 Report for equipment – Type of protection "i" (Intrinsic safety).....	12
C.5 Report for enclosures and transformers – Type of protection "p" (Pressurized) .....	13
C.6 Report for motors – Type of protection "e" (Increased safety) .....	14
C.7 Report for enclosures – Type of protection "e" (Increased safety).....	16
C.8 Report for equipment within enclosures – Type of protection "e" (Increased safety) .....	17
C.9 Report for motors – Type of protection "n" (Non-sparking).....	18
C.10 Report for enclosures – Type of protection "n" (Non-sparking).....	20
C.11 Report for motors – Type of protection "t" (Protection by enclosure) .....	21
C.12 Report for enclosures – Type of protection "t" (Protection by enclosure) .....	23
C.13 Report for equipment inside enclosures – Type of protection "tD" .....	24
C.14 Assessment of Responsible Persons and Operatives .....	25

## INTERNATIONAL ELECTROTECHNICAL COMMISSION

**IECEX Operational Document 315-5 –****IECEX Certified Service Facilities Scheme –  
Part 5: Repair, overhaul and reclamation of Ex equipment****Additional requirements for IECEX Service Facilities involved  
in the repair, overhaul and reclamation of Ex equipment**

## FOREWORD

This IECEX Operational Document is for use by Service Facilities operating in the IECEX Service Facilities Scheme, as described in IECEX OD ~~30~~13-5.

ExCBs are required to use the requirements of in this document when evaluating Ex Service Facilities, involved in the repair, overhaul and reclamation of Ex equipment.

**Document history**

Date	Summary
2013-03	This original issue Edition 1 of OD 315-5 supersedes OD 015 Version 2 in part and represents the application of a new numbering system.
2021-10	Edition 2.0 published to reflect IEC 60079-19:2019 requirements
<u>2023-MM</u>	<u>Edition 2.1 published as recommended by ExSFC WG5, endorsed by the ExSFC and approved by the ExMC</u>

Address:

IECEX Secretariat c/o IEC Sydney Office  
The Executive Centre  
Australia Square, Level 33  
264 George Street  
Sydney, NSW 2000  
Australia

Contact details:

Tel: ~~+61 2 4628 4690~~

Fax: ~~+61 2 4627 5285~~

[info@iecex.com](mailto:info@iecex.com)

[www.iecex.com](http://www.iecex.com)

## INTRODUCTION

The procedures, techniques, systems and methods of repair as set out in this document are to be followed by Ex Service Facilities involved in the repair, overhaul and reclamation of Ex equipment.

This Operational Document is to be read in conjunction with IEC 60079-19:2019 4<sup>th</sup> Edition and is intended for items not covered by that Standard. Should any conflicts be observed then IEC 60079-19 shall be followed.

Specifications, detailed techniques, and industry practice are reflected in this Operational Document.

Compliance with this Operational Document will require Service Facilities to satisfy the requirements IEC 60079-19:2019, 4<sup>th</sup> Edition.

Where the Ex Equipment being overhauled and repaired is a rotating electric machine the requirements of IEC 60034-23 shall ~~will~~ also ~~have to~~ be satisfied.

To assist with the understanding and use of this Operational Document, the Section and Clause numbering format of IEC 60079-19:2019, 4<sup>th</sup> Edition has been used, to clarify both the stated and additional requirements to the corresponding Clause of IEC 60079-19.

Therefore, it is imperative that this Operational Document be read in conjunction with IEC 60079-19:2019, 4<sup>th</sup> Edition.

Readline Version

## IECEX Certified Service Facilities Scheme – Part 5: Repair, overhaul and reclamation of Ex equipment

### Additional requirements for IECEX Service Facilities involved in the repair, overhaul and reclamation of Ex equipment

#### 1. Scope

This Operational Document OD 315-5 does not introduce technical requirements beyond those contained in IEC 60079-19 however it does include additional guidance aimed at ensuring consistency among Ex repair, overhaul and reclamation Service Facilities covered by IECEX certification.

#### 2. Normative references

There is no additional information to the requirements of IEC 60079-19.

#### 3. Definitions and terms

There is no additional information to the requirements of IEC 60079-19.

#### 4. Additional requirements associated with efficiency to maintain T Ratings of rotating machines

When rewinding Ex motors an IECEX Certified Service Facility needs to ensure that their rewind processes do not adversely affect the efficiency of the motor.

Any reduction in efficiency will increase the losses within the machine which will increase surface temperatures and potentially this could exceed the protection concept temperature class.

Guidance on how to rewind motors without adversely affecting their efficiency is freely available from EASA and AEMT.

The document is titled *The Effect of Repair/Rewinding on Motor Efficiency*. This is available as [IECEX OD 301](#) from the IECEX website [www.iecex.com/publications](http://www.iecex.com/publications).

IECEX Service Facilities rewinding Ex motors should be able to demonstrate to their IECEX CB how they meet the EASA and AEMT guidance on how to maintain efficiency when rewinding Ex motors via their procedures and competency training.

#### 5. Additional requirements: Protection "d" – Flameproof enclosures

For IECEX Service Facilities Scheme, the requirements of IEC 60079-19 apply, plus the following:

##### 5.1 Machining limits for flameproof surfaces

The additional information in Annex [A.2B-2](#) of this document provides general limits for machining.

---

## 5.2 Over-pressure test

Where the Service Facility has doubt or questions the validity of documentation or the integrity of the enclosure, the following tests should be considered.

For flameproof protection type "d" enclosures – an over-pressure test in accordance with Annex ~~A.1B.4~~ to the following:

The pressure to be used for the over-pressure test should be either the value mentioned in the certification documents for such purpose or 1.5 times the explosion pressure (reference pressure).

NOTE Reference pressure information should be obtained from the Ex equipment manufacturer.

If neither the over-pressure test value nor the reference pressure test value are known, the values for the pressure test should be according to IEC 60079-19, Clause 5.2.1.2 "Over-pressure testing".

Where welding repairs may affect the integrity of the Ex "d" enclosure an over-pressure test shall be conducted as a practical method to test the integrity of the welding.

## 6. Additional requirements for rotating electric machines

For the IECEX Service Facilities Scheme the requirements of IEC 60034-23 apply in addition to the requirements of IEC 60079-19.

The additional information in Annex C of this document provides a basic framework to assess a service facility.

## **6.7. Knowledge, skills and competencies of Responsible Persons and Operatives in accordance with IEC 60079-19 Annex B**

The ExCB shall obtain a demonstration of competency for each Responsible Person and Operative in accordance with IEC 60079-19 Annex B, and Unit of Competency Ex 005 (overhaul and repair of explosion-protected equipment), set forth in IECEX OD 504 (Specification for Units of Competency Assessment Outcomes), except where such competent persons hold current IECEX CoPC Unit of Competency Ex 005.

NOTE Annex ~~C.14A.14~~ of this Operational Document provides a basic framework to develop an assessment of knowledge that needs to be expanded and tailored to suit each situation.



## Annex A (informative)

### Additional information on over-pressure test procedure and machining limits

#### A.1 Over-pressure test procedure

##### A.1.1 Introduction

There are two methods suitable for the over-pressure test. These are:

1. dial gauge measurement; and
2. straightedge and feeler gauge measurement.

Typical test rigs for both of these methods are shown in (Figure [A.B.1](#)).

##### A.1.2 Test procedure

The procedure should~~all~~ be as follows:

- a) Check the test piece with the original drawings (that is, the dimensional check). The following faces shall be checked with a straightedge and feeler gauge:
  - Flamepaths on enclosure or covers.
  - Flat surfaces which will show up on the drawings as the weakest sections of the enclosure.
  - Flanges on pressurized enclosures.

For dial gauge measurement (Figure [B.1](#)) install dial gauges to surfaces on top, back, front and sides of test piece.

For straightedge and feeler gauge measurement (Figure [A.B.2](#)) draw a line where the straightedge is placed and mark along this line (+) or (-) deformations around the test piece.

Seal the test piece and fill with the testing fluid, taking care that trapped air is minimized. A pressure gauge shall then be fitted to the test piece to check the pressure at the test piece, and also to crosscheck the gauge fitted in the vicinity of the regulator.

Air or gas testing fluid is recommended only for pressurized enclosures, where relatively low pressures are involved.

Apply pressure gradually until the test pressure figure is reached. A safety face shield shall be worn while a visual inspection is made to check for cracks or flaws in the test piece.

The pressure for the over-pressure test shall be held for 1 minute for flameproof enclosures and 5 minutes for pressurized enclosures.

NOTE 1 The pressure to be used for the over-pressure test should be either the value mentioned in the certification documents for such purpose or 1.5 times the explosion pressure (reference pressure).

NOTE 2 If neither the over-pressure test value nor the reference pressure test value are known, the values of Clause 5.2 shall apply. Remove the pressure source and the testing fluid and open up the test piece for inspection.

NOTE 3 For dial gauge measurement (Figure [A.B.1](#)) record difference in dial gauge readings.

NOTE 4 For straightedge and feeler gauge measurement (Figure [A.B.2](#)) place the straightedge on the marked areas and compare to determine the deformation (if any) due to the over-pressure test.

NOTE 5 For flameproof enclosures, give particular attention to the flamepaths, as these are the most important sections. Flat sections manufactured from steel or metals having a high elongation factor may show minor deformation, but this may not take away from the structural strength of the enclosure. Threaded entries and fasteners should be checked for deformation.

### A.1.3 Reporting of results

The test should be considered satisfactory if the enclosure has not suffered structural damage or permanent deformation that may affect its explosion-protection properties.

### A.1.4 Interpretation of results

The extent of permanent deformation reported after over-pressure test should not exceed 0.25 mm per 300 mm when measured with a dial indicator; at the typical points depicted by the following (Figure B.2). This may be taken to be the geographical centre of those parts of the enclosure that are considered to have the least strengthening support.

Permanent deformation is the difference between measurements taken before and after the application of the required pressure test.

Measurements shall be taken at atmospheric pressure.

Where the enclosure area being measured is rectangular, the measurement to be used shall be that across the shortest side. Where this side is greater than 300 mm, the measurement shall be taken across the total length of side and the total amount of deformation shall be calculated from the above requirement.

### Important

Following the over-pressure test, a test of joint surfaces using a straightedge should result in deviations over any 300 mm length of flange not exceeding one half of the flamepath gap as specified in IEC 60079-1.

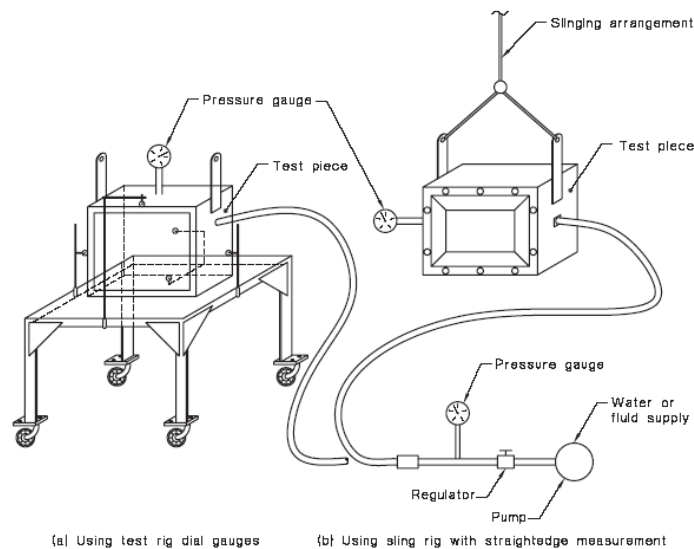
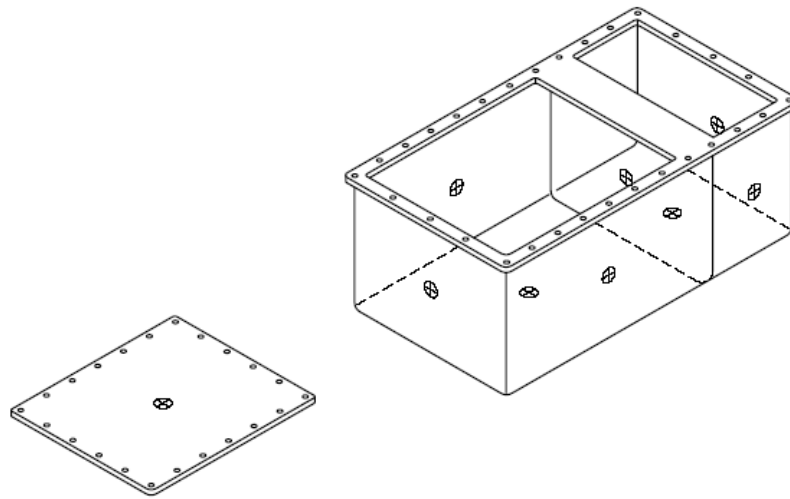

Figure AB.1 – Example of over-pressure test rig



NOTE It is permissible to apply pressure to an enclosure prior to the over-pressure test to release stresses and elasticity of a protection type "d" enclosure.

**Figure AB.2 – Test points for deformation testing during over-pressure test**

## A.2 Machining limits

After repair, tests and measurements should be performed as agreed when the repair work was accepted by the Service Facility.

Where the work involved is confined to machining flameproof surfaces, certification and approval will not be considered invalidated, provided that the cumulative effect of such machining does not:

- a) reduce the flanges below the minimums where the minimum dimension of the thickness of flanges is detailed in the schedule drawings;
- b) alter the volume of the enclosure (without internal parts) by more than 0.5%;
- c) reduce the length of any flamepath whether plain or threaded;
- d) change the surface roughness of machined flame path surfaces, that is, as i.e. compared to undamaged flamepath surfaces; or
- e) result in any deviation to the requirements of the relevant Standards, that is, i.e. the Standard the item was certified to.

Where the Service Facility has doubt or questions the validity of documentation or the integrity of the enclosure, the over-pressure test of Clause 5.2 should be considered.

## Annex B (informative)

### Additional information for compliance with IEC60034-23

This Annex contains examples of evidence for compliance with IEC 60034-23

#### B.1 General

The Service Facility audit should provide evidence that: -

- a) work areas are clean, adequately organised and controlled personnel training records maintained. QMS includes requirements for IEC 60034-23

#### B.2 Specific requirements

The Service Facility audit should provide evidence that: -

- a) Identification and condition assessment
  - user's reason for repair
  - job number marked on equipment
  - record of inspection i.e physical condition, mechanical damage, soft foot, overheating.
  - Cause of failure identified and recorded
  
- b) Terminal box
  - inspected for damage
  - terminal leads clearly labelled
  - terminal lugs correctly crimped
  - replacement lead size and type documented
  - crimping tool function checked every quarter year
  - gaskets inspected for damage
  
- c) Cooling System
  - fan & fan cover
  - evidence of damaged or missing cooling system parts
  - Location of air baffles and endwinding blocking system spaces if rewound
  - visible evidence of leaks on air / water heat exchangers
  - gaskets between heat exchanger and frame inspected
  
- d) Shafts
  - visible evidence of shaft damage (keyway damage or cracks) or wear
  - position of terminal box in relation to shaft
  - initial and, if applicable, after repair shaft dimensions and runout to be recorded
  - dial indicators to be verified by service facility or calibration

e) Bearings

- visual inspection for evidence of fretting, fluting, scoring, spalling or other damage (white metal) as appropriate and may require disassembly of the bearing to enable this inspection
- as received, and if repaired, post repair bearing fit dimensions recorded
- rolling element bearing fits verified
- replacement bearings equivalent to the original. Original and replacement bearing identification number and codes recorded

f) Lubrication

- verify lubricant used by customer is compatible and record lubricant used
- bearing lubricated to manufacturers requirements, if not available 1/3<sup>rd</sup> fill
- oil lubricated bearing site glass clear & correct indication
- oil lubricated bearing leak check

g) Frame and bearing housings

- frame and bearing housing integrity checked and evidence of damage
- parts correctly match marked according to the Service Facility's procedure

h) ~~Squirrel-cage~~ Rrotors (of all types)

- check for evidence of rotor damage
- check rotor core tight to shaft or spider
- rotor cage checked, tested as appropriate to machine size, and recorded
- electrical and mechanical characteristics are maintained and any repair method used recorded
- verify growler functionality

i) Balancing

- dynamic balancing as specified by user or to ISO quality grade G2.5 for machines <2,500 RPM or G 1.0 for machines > 2,500 RPM. Vibrator rotors do not require balancing
- balance weights location does not affect other components and are securely attached
- balancing machine calibrated and functionally checked

j) Accessories

- space heaters inspected for damage, tested at nominal voltage after an IR test
- winding temperature sensors replaced with same type and location(s) in stator core and tested before and after winding
- defective bearing sensors replaced with identical or equivalent devices
- shaft speed sensors replaced with identical or equivalent devices

k) Winding removal & core integrity

- core flux test conducted before and after burnout or equivalent process hot spot temperatures and W/kg recorded
-

- core is repaired or replaced when core losses increase >20% (this is reduced to 10% for Ex equipment as per IEC 60079-19) before and after tests
- burnout oven temperature max 370°C with temperature recorder and functional water mist or other temperature control system functional
- parts orientated and located to avoid distortion
- core checked after cleaning free of contamination and sharp edges
- core verified for tightness and core damage including displaced end of core laminations
- burnout oven calibrated

l) Rewind data details

- winding data from original winding verified and recorded
- winding data verified for suitability
- changes from original winding data recorded

m) Stator winding, insulation system, conductors & coils

- insulation class and voltage equal to original
- coil straight lengths maintained or reduced
- winding projection not greater than original
- conductor cross-sectional area not less than the original
- round wire windings have full length slot closers/wedges and phase insulation is used
- formed coils tightly wedges with wedges tight in wedge groove
- magnetic wedges replaced with equivalent magnetic wedges
- coil winder counter verified by service facility

n) Winding impregnation

- stators with replacement windings pre-heated, impregnated and cured in accordance with varnish/resin manufacturer's instructions
- curing oven temperature and duration is in accordance with varnish/resin manufacturer's instructions
- varnish/resin is maintained and tested in accordance with manufacturer's instructions, test results and actions to maintain compliance recorded

o) Winding test

- Winding temperature and insulation resistance measured, verified and recorded
- Winding resistance measured, verified and recorded
- Polyphase winding surge comparison tested verified and recorded
- Surge tester calibrated and functionality checked

p) Voltage withstand test

- Voltage withstand test of new windings and accessories conducted as IEC 60034-1 and recorded
- Overhauled windings withstand tested at voltage specified by user
- Overhauled windings and accessories insulation resistance measured and recorded

q) Bearing insulation test

- Where applicable bearing insulation is measured, verified and recorded

r) No load test

- No-Load running test conducted at nominal voltage unless agreed with the user
- shaft speed measured, verified and recorded
- no-load voltages, phase currents, phase current unbalance are measured and recorded
- machine vibration measured, verified -and recorded
- bearing temperatures measured, verified and recorded
- machine assessed for compliance with user requirements and suitability for release to user

s) Finishing & handling

- machine clean and painted (paint should not block any critical openings)
- shaft extensions treated to prevent corrosion
- machine packed and protected suitable for the method of transportation
- Oil lubricated machines shipped without oil should have -clear warnings that oil is required before operation

### **C.1 Service Facility Equipment**

The Service Facility should have as a minimum the following equipment calibrated, functional and available on site.

a) Electrical

- ohmmeter
- milli-ohmmeter
- voltmeter (AC & DC)
- ammeter (AC & DC)
- wattmeter (AC)
- megohmmeter
- voltage withstand tester
- surge tester
- proprietary core tester or ring flux test equipment and power supply
- growler
- no-load test panel

b) Mechanical

- inside micrometers
  - outside micrometers
  - surface table or equivalent
  - straight edge
  - vernier
  - gauge blocks
-

- rule
- dial gauges
- digital tachometer
- terminal lug crimpers
- vibration measurement equipment
- dynamic balancing machine

c) Physical

- Temperature meter
- Burnout over temperature control and temperature recorder
- Burnout oven water mist or equivalent -control system
- Curing oven temperature control and temperature recorder
- Winding machine turns counter
- VPI vacuum gauge where VPI impregnation used
- VPI pressure gauge where VPI impregnation used
- Paint layer thickness measurement for Ex equipment

Readline Version



~~Annex B~~ **Annex C**  
(informative)  
**Recommended report form**

This Annex contains a collection of standardized report forms that may be used by Service Facilities involved in the repair, overhaul or reclamation of Ex equipment.

While Ex Service Facilities are ~~permitted~~ **free** to use their own report formats, those used by the Service Facility should contain the same level of information as that detailed in these sample forms.

ExCBs shall use this Annex as a guide when determining the suitability of such forms used by Service Facilities in the IECEx Service Facilities Scheme.

Readline Version

**B.1C.1 Report for motors – Type of protection "d" (Flameproof)**

Report no.:..... Certificate no.:.....	<u>Flameproof Motors:</u>
Name of Service Facility .....	Shaft flameproof Gland diametral clearance
Service facility recognition no.: .....	– D.E.:.....mm
.....	N.D.E.: .....mm
Location: .....	Endplate spigot diametral clearance
.....	– D.E.: .....mm
.....	N.D.E.: .....mm
Country:.....	Cable gland and gland spigot diametral
Motor description: .....	clearance: .....mm
Serial no.:..... Owner: .....	Screwed cable gland no. of threads
.....	engaged: .....
Order no.:..... Date received: .....	Screwed hand hole covers no. of threads
.....	engaged .....
Motor condition when dismantled:	Condition of bolt holes: .....
<i>Drive End D.E; Non Drive End N.D.E</i>	Terminal box:
Bearings and seals – D.E.:... N.D.E.: .....	Deviation of flanged joint surfaces (max): mm
Bearing journals – D.E.: ... N.D.E.: .....	Flamepath gap after assembly:.....mm
Seals journals – D.E.: .. N.D.E.: .....	Water jacket:
Bearings housings – D.E.: ... N.D.E.: ...	Jacket volume test before descaling:.....litres
.....	Jacket thickness:.....mm
Stator and windings:.....	Jacket pressure test:..... kPa at:..... °C
.....	Pass: ..... Fail:.....
.....	Jacket descaled by using: .....
Rotor/armature and windings:.....	Volume test after descaling:..... litres
.....	Flow test:..... litres/min
.....	Static pressure test:
Items missing on receipt of motor: .....	Terminal boxes:..... kPa
.....	Motor enclosures:..... kPa
.....	Tests:
General motor condition: .....	Insulation test to frame: .....Volt megger
.....	Stator/fields: ..... Rotor/Armature:.....
.....	Test run for 1 hour – phase Currents –
.....	A: .....
.....	B: .....
.....	C: .....
Bearing make and no. – D.E.:...N.D.E.: ...	Core test – stator: Rotor:.....
Seal make and no. – D.E.:..... N.D.E.: ...	Previous core test – Stator: Rotor:.....
Replacement shaft manufacturer: .....	

Certification drawing no(s):.....

Certification marking: .....

I,.....confirm that the above equipment has been repaired and repaired/overhauled in accordance with IEC 60079-19. The marking complies with Annex A of the standard.

Summary of identification of released product:

- a) Product conforms to original standard and certification documents **YES / NO**
- b) Restrictions apply to use of this product as originally certified **YES / NO**
- c) Compliance of the product has been verified by a competent person **YES / NO / NA**

*Mark which applies to released product.*

Name of Responsible Person: ..... Signature: .....

Service Facility Record number: .....Date: . . / . . / . .

**B.2C.2 Report for enclosures – Type of protection type "d" (Flameproof)**

Report no.: .....

Certificate no.: .....

Name of overhaul service facility: .....

Service facility recognition no.: .....

Address: .....

Postcode: ..... Telephone no.: ..... Fax no.: .....

Enclosure description: .....

Serial no.: ..... Owner: .....

Order no.: ..... Date received: . . . / . . . / . . .

Item	Description of check	Remarks
(a)	Check of external and internal damage	
(b)	Dimensional check	
(c)	Corrosion on flamepaths	
(d)	Result of static pressure test	
(e)	Check of flanged joint surfaces	
(f)	Check of all threaded holes	
(g)	Check of all windows and lenses	
(h)	Check of breathers	
(i)	Check of all bolt holes, studs, screws, etc.	
(j)	Check of all gland entries and fixing holes	
(k)	Check of all cables glands	
(l)	Check of all handhole and inspection covers	
(m)	Check of all mechanical interlocks	
(n)	Check of all flamepath gaps	

Main control panel

1 Max. out of plane of box flanges: .....

2 Max. out of plane of cover: .....

3 Max. flameproof gap when bolted up: .....

4 Max. diametral clearance of spindles: .....

5 Max. diametral clearance of gland to gland apertures: .....

6 Static pressure test – pressure: .....

7 Water jacket – pressure test: ..... Capacity: .....

Certification drawing no(s): .....

Certification marking: .....

I, ..... confirm that the above equipment has been repaired and repaired/overhauled in accordance with IEC 60079-19. The marking complies with Annex A of the standard.

Summary of identification of released product:

a) Product conforms to original standard and certification documents **YES / NO**b) Restrictions apply to use of this product as originally certified **YES / NO**c) Compliance of the product has been verified by a competent person **YES/NO/NA***Mark which applies to released product.*

Name of Responsible Person: ..... Signature: .....

Service Facility Record number: ..... Date: . . / . . / . . .

**B.3C.3 Report for equipment installed within enclosures – Type of protection type "d" (Flameproof)**

Report no.: .....

Certificate no.: .....

Name of overhaul service facility: .....

Service facility recognition no.: .....

Address: .....

Postcode: ..... Telephone no.: ..... Fax no.: .....

Description of unit: .....

Owner: ..... Order no.: .....

Serial no of enclosure this test certificate applies to.: .....

Enclosure test certificate no.: ..... Date received: ./. /.

Item	Description of check	No work required	Overhauled	Repaired	Replaced (R) Modified (M)
(a)	Isolator mechanism and switch operation				
(b)	Earthing device and operation				
(c)	All auxiliary mechanisms, trip bars, latching arrangements, etc.				
(d)	All locking devices, function and operation				
(e)	All parts for mechanical condition				
(f)	All insulation checked – no heat, cracks, etc.				
(g)	Phase barriers fitted correctly and functional				
(h)	Oil levels and/or gas pressure				
(i)	Gas pressure-sensing devices				
(j)	All wiring and terminations				
(k)	Earth continuity; phase/earth fault lock units				
(l)	Overcurrent, overload and earth-fault devices				
(m)	Earth-fault trip devices				
(n)	Timing devices				
(o)	Temperature-sensing devices				
(p)	Transformer connections, bolts, tapes, bracing, insulators and fittings etc.				
(q)	Installation				
(r)	Machine cables and glands				

Details of overhaul, repair or modification (attach extra pages if required):

Results of insulation resistance tests on transformers:

Transformer ratio: ..... Capacity: ..... Serial no: .....

Manufacturer: ..... Type of cooling: .....

Tested with: ..... V (Megohmmeter)

Primary winding to secondary winding: ..... MΩ

Primary winding to earth: ..... MΩ

Secondary winding to earth: ..... MΩ

Earth continuity of earth screen to core: .....

Assembled unit tested for insulation resistance with:V megohmmeter, and power frequency tested on the following circuits:

Circuit description	Insulation resistance MΩ	Test voltage kV	Test frequency Hz	Result

Certification drawing no(s): .....

Certification marking: .....

I, .....confirm that the above equipment has been repaired and repaired/overhauled in accordance with IEC 60079-19. The marking complies with Annex A of the standard.

Summary of identification of released product:

- a) Product conforms to original standard and certification documents **YES / NO**
- b) Restrictions apply to use of this product as originally certified **YES / NO**
- c) Compliance of the product has been verified by a competent person **YES/ NO /NA**

*Mark which applies to released product.*

Name of Responsible Person: ..... Signature: .....

Service Facility Record number: ..... Date: . . / . . / . . / . .

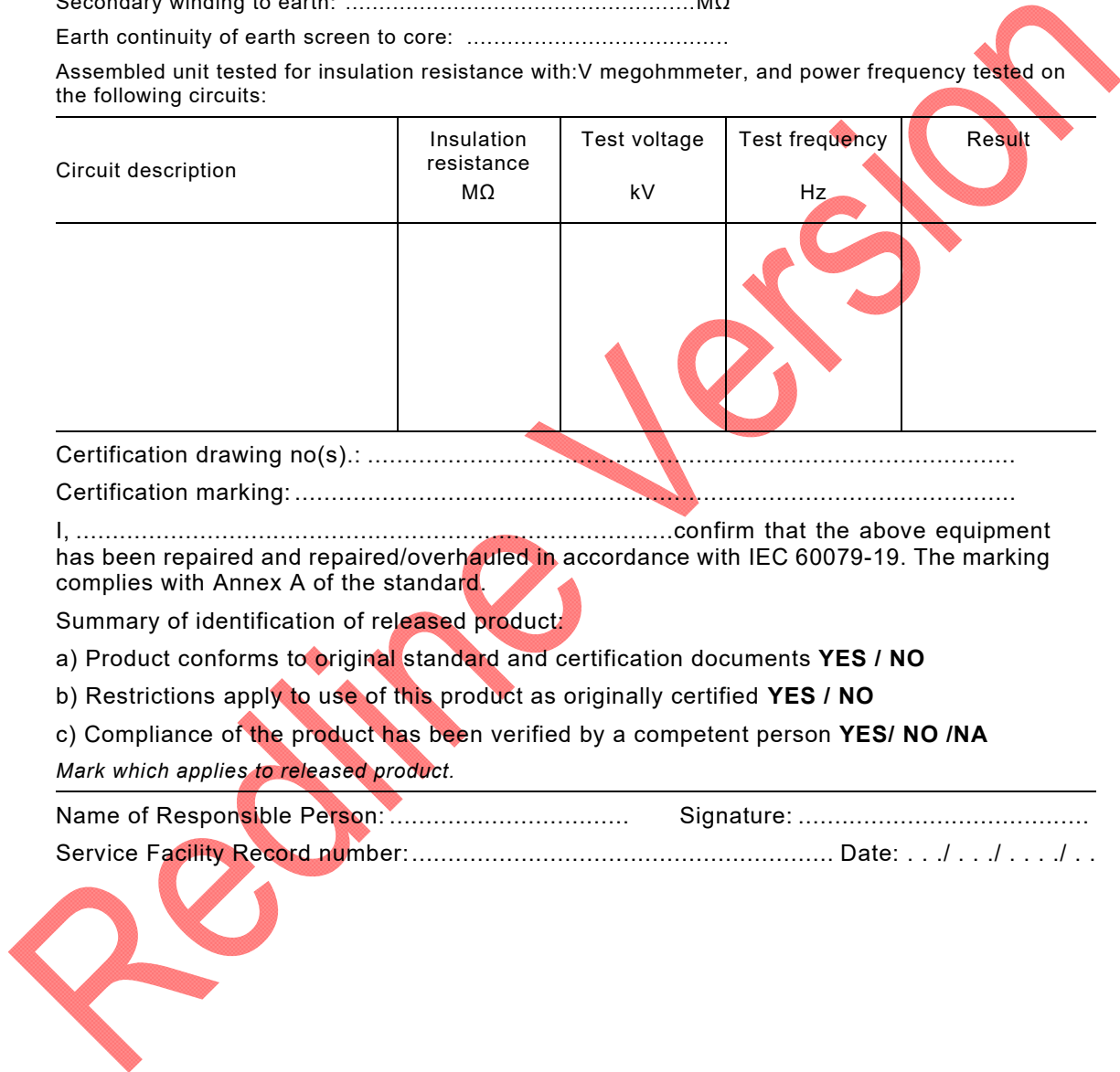

**B.4C.4 Report for equipment – Type of protection "i" (Intrinsic safety)**

Report no.: ..... Certificate no.: .....

Name of overhaul service facility: .....

Service facility recognition no.: .....

Address: .....

Postcode: ..... Telephone no.: ..... Fax no.: .....

Equipment description: .....

Owner: ..... Order no.: .....

Serial no.: ..... Date received: . . . / . . . / . . .

Condition upon receipt: ..... Old repair label details: .....

..... Cert no.: .....

---

Reported fault (if any): .....

---

Repair action: .....

Parts replaced: .....

---

Tests performed: .....

Results: .....

---

Certification drawing no(s): .....

Certification marking: .....

I, ..... confirm that the above equipment has been repaired and repaired/overhauled in accordance with IEC 60079-19. The marking complies with Annex A of the standard.

Summary of identification of released product:

a) Product conforms to original standard and certification documents **YES / NO**

b) Restrictions apply to use of this product as originally certified **YES / NO**

c) Compliance of the product has been verified by a competent person **YES/ NO /NA**

*Mark which applies to released product.*

---

Name of Responsible Person: ..... Signature: .....

Service Facility Record number: ..... Date: . . / . . / . . . . / . .



**B.5C.5** Report for enclosures and transformers – Type of protection "p"  
(Pressurized)

Report no.: ..... Certificate no.: .....

Name of overhaul service facility: .....

Service facility recognition no.: .....

Address: .....

Postcode: ..... Telephone no.: ..... Fax no.: .....

Equipment description: .....

Owner: ..... Order no.: .....

Serial no: ..... Date received: . . . / . . . / . . .

Condition upon receipt: ..... Old repair label details: .....

..... Cert no.: .....

Reported fault (if any): .....

Repair action: .....

Parts replaced: .....

Tests performed: .....

Results: .....

Certification drawing no(s): .....

Certification marking: .....

I, ..... confirm that the above equipment has been repaired and repaired/overhauled in accordance with IEC 60079-19. The marking complies with Annex A of the standard.

Summary of identification of released product:

- a) Product conforms to original standard and certification documents **YES / NO**
- b) Restrictions apply to use of this product as originally certified **YES / NO**
- c) Compliance of the product has been verified by a competent person **YES/ NO /NA**

*Mark which applies to released product.*

Name of Responsible Person: ..... Signature: .....

Service Facility Record number: ..... Date: . . / . . / . . / . .



**B.6C.6 Report for motors – Type of protection "e" (Increased safety)**

Report no.: ..... Certificate no.: .....

Name of overhaul service facility: .....

Service facility recognition no.: .....

Address: .....

Postcode: ..... Telephone no: ..... Fax no.: .....

Motor description: .....

Owner: ..... Order no.: .....

Serial no: ..... Date received: . . . / . . . / . . .

Motor condition when received: Old repair label no.: .....

External surfaces cleaned for inspection –

Fan cowls and fans:.....

Stator case and cooling fins:..... Corrosion:.....

Endshields and fasteners:..... Bearing caps:.....

Ducts and piping: ..... Grease relief:.....

Terminal box cover and gaskets:.....

Gland entries: ..... Glands:.....

General external condition: .....

Missing parts:.....

Motor dismantled:..... Degree of protection: IP .....

Internal condition – Evidence of dust or liquids: ...

*Drive End D.E; Non Drive End N.D.E*

Bearings and seal – D.E.: ..... Bearing journals – D.E.: .....

N.D.E.: ..... NDE.: .....

Seals journals – D.E.: ..... Bearing housings – D.E.: .....

N.D.E.: ..... N.D.E.: .....

Stator windings and iron circuit: .....

Rotor cage and iron circuit:.....

Internal fan clearance:.....

Details of motor repair: .....

.....

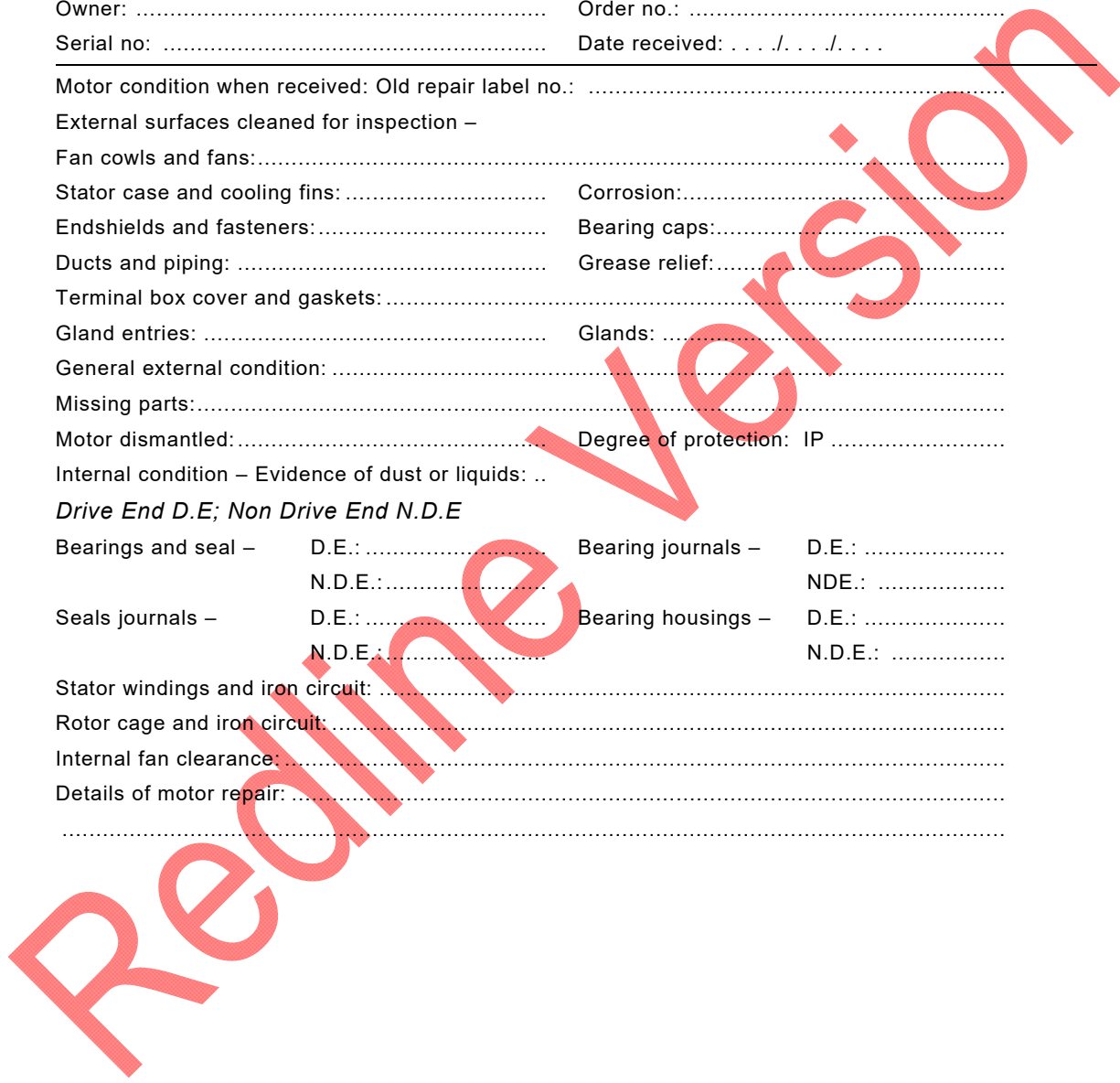



Ex 'e' motor

Cover and fasteners: ..... Condition of fastener holes: .....

Gasket: ..... Gland entries: .....

Terminals type: ..... Certificate no.: .....

Cable lugs type: ..... Sleeving fitted .....

Stator – Diameter: .....

Winding to original certification: ..... or modified: .....

Rotor – Diameter: .....

Radial gap: .....

Replaced – Radial gap: ..... Overload type: .....

Tests:

Resistance cold (ohms) – Ambient Temp. ....C Phases – A ..... B ..... C .....

Core test – Previous stator: ..... Rotor: .....

– Present stator: ..... Rotor: .....

Insulation test to frame: ..... Phase/Phase: A ..... B ..... D .....

H.V. test to IEC 60079-7 ..... kV for 1 min

No load running – Vibration: ..... Noise: ..... Bearing heat: .....

Phase balance – Reduced voltage: A ..... B ..... C .....

(at full load amps) (Locked rotor)

OR Rated full load: A ..... B ..... C .....

Temperature increase test – Full load: ..... K Temperature class: T .....

Locked rotor: ..... I<sub>A</sub> / I<sub>N</sub> tE ..... s.

Certification drawing no(s): .....

Remarks: .....

Certification drawing no(s): .....

Certification marking: .....

I, ..... confirm that the above equipment has been repaired and repaired/overhauled in accordance with IEC 60079-19. The marking complies with Annex A of the standard.

Summary of identification of released product:

a) Product conforms to original standard and certification documents **YES / NO**

b) Restrictions apply to use of this product as originally certified **YES / NO**

c) Compliance of the product has been verified by a competent person **YES/ NO /NA**

*Mark which applies to released product.*

Name of Responsible Person: ..... Signature: .....

Service Facility Record number: ..... Date: . . / . . / . . . . / . .

**B.7C.7** Report for enclosures – Type of protection "e" (Increased safety)

Report no.: ..... Certificate no.: .....

Name of overhaul service facility: .....

Service facility recognition no.: .....

Address: .....

Postcode: ..... Telephone no: ..... Fax no.: .....

Enclosure description: .....

Owner: ..... Order no.: .....

Serial no: ..... Date received: . . . / . . . / . . .

Enclosure condition when received: Old repair label no.: .....

External surfaces cleaned for inspection –

Covers and fasteners:..... Base of enclosure:.....

Threaded holes:..... External corrosion:.....

Surface coating:..... Gland entries and glands:.....

General external condition: .....

Enclosure dismantled:..... Degree of protection: IP .....

Internal condition – Dust:..... Corrosion:.....

or, evidence of liquids:..... Heat:.....

Missing parts:.....

Cables and terminations:..... Terminal blocks:.....

Earth terminals:..... General insulation:.....

Windows and seals:..... Actuators and seals:.....

Ex 'de' parts:..... Meters:.....

Lamps:..... Transformers:.....

Switches:..... Other:.....

Relays:..... Interlocks:.....

Luminaire:..... Lamp type and power (W):.....

Transparent part:..... Lampholders:.....

Ballasts:..... Capacitors:..... Batteries:.....

Certification drawing no(s): .....

Certification marking: .....

I, ..... confirm that the above equipment has been repaired and repaired/overhauled in accordance with IEC 60079-19. The marking complies with Annex A of the standard.

Summary of identification of released product:

a) Product conforms to original standard and certification documents **YES / NO**

b) Restrictions apply to use of this product as originally certified **YES / NO**

c) Compliance of the product has been verified by a competent person **YES/ NO /NA**

*Mark which applies to released product.*

Name of Responsible Person: ..... Signature: .....

Service Facility Record number: ..... Date: . . / . . / . . . / . .

### **B.8C.8** Report for equipment within enclosures – Type of protection "e" (Increased safety)

Report no.: .....

Certificate no.: .....

Name of overhaul service facility: .....

Service facility recognition no.: .....

Address: .....

Postcode: ..... Telephone no.: ..... Fax no.: .....

Description of unit: .....

Owner: ..... Order no.: .....

Serial no of enclosure this test certificate applies to.: .....

Enclosure test certificate no.: ..... Date received: . / . / .

Item	Description of check	No work required	Overhauled	Repaired	Replaced (R) Modified (M)
(a)	Ex 'e' lamp				
(b)	Ex 'e' switch				
(c)	Ex 'e' meter – calibrate				
(d)	Switch actuator – check all seals and action				
(e)	Terminal blocks – check for heat and insulation cracks				
(f)	Bushings and insulation condition				
(g)	Cables – insulation, lugs and sleeving				
(h)	Transformer connections, tapes, bracing insulators, terminal				
(i)	Temperature sensing devices				
(j)	Mechanical interlocks				
(k)	All insulation checked – no heat				
(l)	Heaters – check condition				

Certification drawing no(s): .....

Certification marking: .....

I, ..... confirm that the above equipment has been repaired and repaired/overhauled in accordance with IEC 60079-19. The marking complies with Annex A of the standard.

Summary of identification of released product:

a) Product conforms to original standard and certification documents **YES / NO**b) Restrictions apply to use of this product as originally certified **YES / NO**c) Compliance of the product has been verified by a competent person **YES/ NO /NA**

Mark which applies to released product.

Name of Responsible Person: ..... Signature: .....

Service Facility Record number: ..... Date: . / . / .

**B.9C.9 Report for motors – Type of protection "n" (Non-sparking)**

Report no.: ..... Certificate no.: .....

Name of overhaul service facility: .....

Service facility recognition no.: .....

Address: .....

Postcode: ..... Telephone no.: ..... Fax no.: .....

Motor description: .....

Owner: ..... Order no.: .....

Serial no.: ..... Date received: . . . / . . . / . . .

Motor condition when received: Old repair label no.: .....

External surfaces cleaned for inspection –

Fan cowls and fans:.....

Stator case and cooling fins:..... Corrosion: .....

Endshields and fasteners:..... Bearing caps: .....

Ducts and piping:..... Grease relief:.....

Terminal box cover and gaskets:.....

Gland entries:..... Glands:.....

General external condition: .....

Missing parts:.....

Motor dismantled:..... Degree of protection: IP .....

Internal condition – Dust:.....

or, evidence of liquids:.....

*Drive End D.E; Non Drive End N.D.E*

Bearings and seal – D.E.:..... Bearing journals – D.E.:.....

N.D.E.:..... NDE.:.....

Seals journals – D.E.:..... Bearing housings – D.E.:.....

N.D.E.:..... N.D.E.:.....

Stator windings and iron circuit:.....

Rotor cage and iron circuit:.....

Internal fan clearance:.....

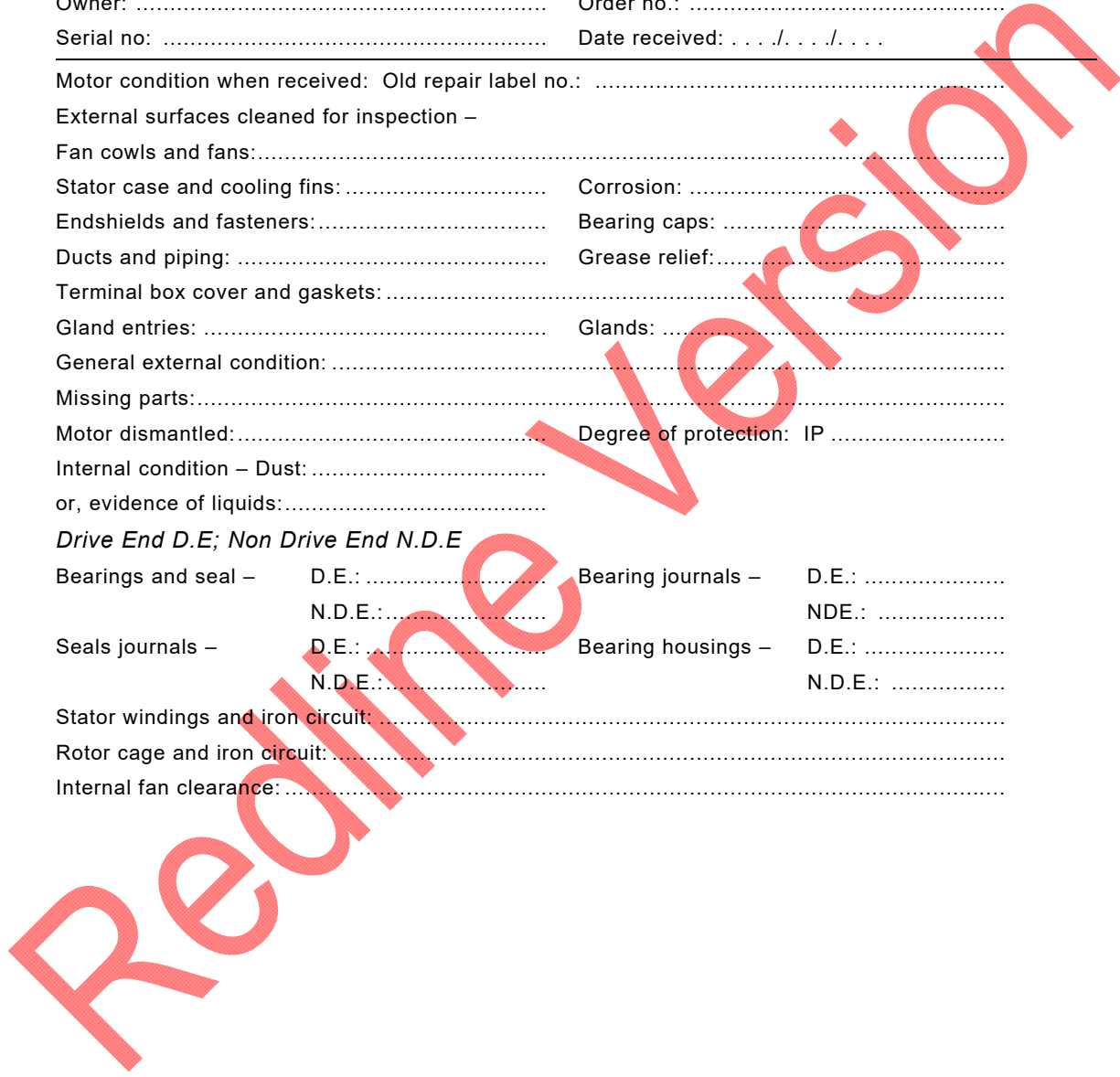

Details of motor repair: .....

Ex 'n' motor

Cover and fasteners: ..... Condition of fastener holes: .....

Gasket: ..... Gland entries: .....

Terminals type: ..... Certificate no.: .....

Cable lugs type: ..... Sleeving fitted: .....

Stator – Diameter: .....

Winding to original certification: ..... or modified: .....

Rotor – Diameter: .....

Radial gap: .....

Replaced – Radial gap: ..... Overload type: .....

Tests:

Resistance cold (ohms) – Ambient Temp ..... C Phases – A ..... B ..... C .....

Core test – Previous stator: ..... Rotor: .....

– Present stator: ..... Rotor: .....

Insulation test to frame: ..... Phase/Phase: A ..... B ..... D .....

H.V. test to IEC 60079-15: ..... kV for 1 minute.

No load running – Vibration: ..... Noise: ..... Bearing heat: .....

Phase balance – Reduced voltage: A ..... B ..... C .....

(at full load amps) (Locked rotor)

OR Rated full load: A ..... B ..... C .....

Temperature increase test – Full load: ..... K Temperature class: T .....

Certification drawing no(s): .....

Certification marking: .....

I, ..... confirm that the above equipment has been repaired and repaired/overhauled in accordance with IEC 60079-19. The marking complies with Annex A of the standard.

Summary of identification of released product:

a) Product conforms to original standard and certification documents **YES / NO**

b) Restrictions apply to use of this product as originally certified **YES / NO**

c) Compliance of the product has been verified by a competent person **YES/ NO /NA**

*Mark which applies to released product.*

Name of Responsible Person: ..... Signature: .....

Service Facility Record number: ..... Date: . . / . . / . . / . .

**B.10C.10 Report for enclosures – Type of protection "n" (Non-sparking)**

Report no.: ..... Certificate no.: .....

Name of overhaul service facility: .....

Service facility recognition no.: .....

Address: .....

Postcode: ..... Telephone no.: ..... Fax no.: .....

Enclosure description: .....

Owner: ..... Order no.: .....

Serial no.: ..... Date received: . . . / . . . / . . .

Enclosure condition when received: Old repair label no.: .....

External surfaces cleaned for inspection –

Covers and fasteners: ..... Base of enclosure: .....

Threaded holes: ..... External corrosion: .....

Surface coating: ..... Gland entries and glands: .....

General external condition: .....

Enclosure dismantled: ..... Degree of protection: IP .....

Internal condition – Dust: ..... Corrosion: .....

or, evidence of liquids: ..... Heat: .....

Missing parts: .....

Cables and terminations: ..... Terminal blocks: .....

Earth terminals: ..... General insulation: .....

Windows and seals: ..... Actuators and seals: .....

Ex 'n' parts: ..... Meters: .....

Lamps: ..... Transformers: .....

Switches: ..... Other: .....

Relays: ..... Interlocks: .....

Luminaire: ..... Lamp type and power (W): .....

Transparent part: ..... Lampholders: .....

Ballasts: ..... Capacitors: ..... Batteries: .....

Enclosure assembled:

Restricted breathing test: ..... Type of test: .....

Certification drawing no(s): .....

Certification marking: .....

I, ..... confirm that the above equipment has been repaired and repaired/overhauled in accordance with IEC 60079-19. The marking complies with Annex A of the standard.

Summary of identification of released product:

a) Product conforms to original standard and certification documents **YES / NO**

b) Restrictions apply to use of this product as originally certified **YES / NO**

c) Compliance of the product has been verified by a competent person **YES/ NO /NA**

*Mark which applies to released product.*

Name of Responsible Person: ..... Signature: .....

Service Facility Record number: ..... Date: . . / . . / . . . / . .

**B.11C.11 Report for motors – Type of protection "t" (Protection by enclosure)**

Report no.: ..... Certificate no.: .....

Name of overhaul service facility: .....

Service facility recognition no.: .....

Address: .....

Postcode: ..... Telephone no.: ..... Fax no.: .....

Motor description: .....

Owner: ..... Order no.: .....

Serial no.: ..... Date received: . . . / . . . / . . .

Motor condition when received: Old repair label no.: .....

External surfaces cleaned for inspection –

Fan cowls and fans: .....

Stator case and cooling fins: ..... Corrosion: .....

Endshields and fasteners: ..... Bearing caps: .....

Ducts and piping: ..... Grease relief: .....

Terminal box cover and gaskets: .....

Gland entries: ..... Glands: .....

General external condition: .....

Missing parts: .....

Motor dismantled: ..... Degree of protection: IP .....

Internal condition – Evidence of dust or liquids: ..

*Drive End D.E; Non Drive End N.D.E*

Bearings and seal – D.E.: ..... Bearing journals – D.E.: .....  
N.D.E.: ..... N.D.E.: .....

Seals journals – D.E.: ..... Bearing housings – D.E.: .....  
N.D.E.: ..... N.D.E.: .....

Stator windings and iron circuit: .....

Rotor cage and iron circuit: .....

Internal fan clearance: .....

Details of motor repair: .....

.....

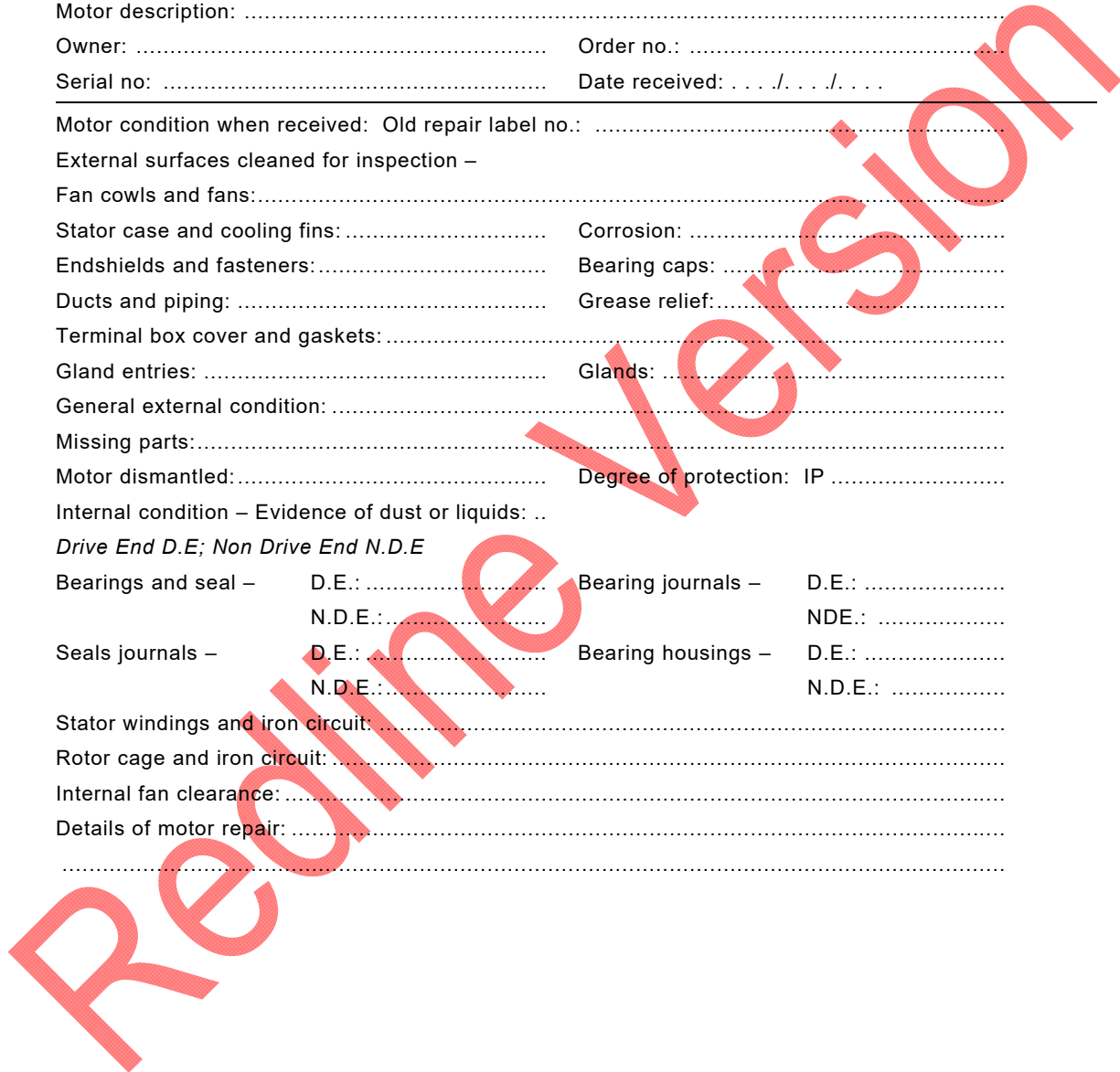

Protection type Ex "t" motor with Ex "t" terminal box: (Refer to Certificate for Ex "t"):

[Type of protection Ex "t" was formerly known as Ex "tD" and DIP.]

Cover and fasteners: ..... Condition of fastener holes: .....

Gasket: ..... Gland entries: .....

Terminals type: ..... Certificate no.: .....

Cable lugs type: ..... Sleeving fitted: .....

2. DIP Motor – Item 1 plus:

Stator – Diameter: .....

Winding to original approval: ..... or Modified: .....

Rotor – Diameter: .....

Radial gap: .....

Replaced – Radial gap: ..... Overload type: .....

Tests:

Resistance cold (ohms) – Ambient Temp ..... C Phases – A ..... B ..... C .....

Core test – Previous stator: ..... Rotor: .....

– Present stator: ..... Rotor: .....

Insulation test to frame: ..... Phase/Phase: A ..... B ..... D .....

H.V. test ..... kV for 1 minute.

No load running – Vibration: ..... Noise: ..... Bearing heat: .....

Phase balance – Reduced voltage: A ..... B ..... C .....

(at full load amps) (Locked rotor)

OR Rated full load: A ..... B ..... C .....

Temperature increase test – Full load: ..... K Temperature class: T .....

Certification drawing no(s): .....

Certification marking: .....

I, ..... confirm that the above equipment has been repaired and repaired/overhauled in accordance with IEC 60079-19. The marking complies with Annex A of the standard.

Summary of identification of released product:

a) Product conforms to original standard and certification documents **YES / NO**

b) Restrictions apply to use of this product as originally certified **YES / NO**

c) Compliance of the product has been verified by a competent person **YES/ NO /NA**

*Mark which applies to released product.*

Name of Responsible Person: ..... Signature: .....

Service Facility Record number: ..... Date: . . / . . / . . / . .



**B.12C.12 Report for enclosures – Type of protection "t" (Protection by enclosure)**

Report no.: ..... Certificate no.: .....

Name of overhaul service facility: .....

Service facility recognition no.: .....

Address: .....

Postcode: ..... Telephone no: ..... Fax no.: .....

Enclosure description: .....

Owner: ..... Order no.: .....

Serial no: ..... Date received: . . . / . . . / . . .

---

Enclosure condition when received: Old repair label no.: .....

External surfaces cleaned for inspection –

Covers and fasteners: ..... Base of enclosure: .....

Threaded holes: ..... External corrosion: .....

Surface coating: ..... Gland entries and glands: .....

General external condition: .....

Enclosure dismantled: ..... Degree of protection: IP .....

Internal condition – Dust: ..... Corrosion: .....

or, evidence of liquids: ..... Heat: .....

Missing parts: .....

Cables and terminations: ..... Terminal blocks: .....

Earth terminals: ..... General insulation: .....

Windows and seals: ..... Actuators and seals: .....

DIP parts: ..... Meters: .....

Lamps: ..... Transformers: .....

Switches: ..... Other: .....

Relays: ..... Interlocks: .....

Luminaire: ..... Lamp type and power (W): .....

Transparent part: ..... Lampholders: .....

Ballasts: ..... Capacitors: ..... Batteries: .....

---

Certification drawing no(s): .....

Certification marking: .....

I, ..... confirm that the above equipment has been repaired and repaired/overhauled in accordance with IEC 60079-19. The marking complies with Annex A of the standard.

Summary of identification of released product:

a) Product conforms to original standard and certification documents **YES / NO**

b) Restrictions apply to use of this product as originally certified **YES / NO**

c) Compliance of the product has been verified by a competent person **YES/ NO /NA**

*Mark which applies to released product.*

---

Name of Responsible Person: ..... Signature: .....

Service Facility Record number: ..... Date: . . . / . . . / . . .

**B.13C.13 Report for equipment inside enclosures – Type of protection "tD"**

Report no.: .....

Certificate no.: .....

Name of overhaul service facility: .....

Service facility recognition no.: .....

Address: .....

Postcode: ..... Telephone no.: ..... Fax no.: .....

Description of unit: .....

Owner: ..... Order no.: .....

Serial no of enclosure this test certificate applies to.: .....

Enclosure test certificate no.: ..... Date received: . / . / . . . . .

Item	Description of work	No work required	Overhauled	Repaired	Replaced (R) Modified (M)
(a)	Lamp				
(b)	Switch				
(c)	Meter – calibrate				
(d)	Switch actuator – check all seals and action				
(e)	Terminal blocks – check for heat and insulation cracks				
(f)	Bushings and insulation condition				
(g)	Cables – insulation, lugs and sleeving				
(h)	Transformer connections, tapes, bracing insulators, terminal				
(i)	Temperature sensing devices				
(j)	Mechanical interlocks				
(k)	All insulation checked – no heat				
(l)	Heaters – check condition				

Certification drawing no(s): .....

Certification marking: .....

I, ..... confirm that the above equipment has been repaired and repaired/overhauled in accordance with IEC 60079-19. The marking complies with Annex A of the standard.

Summary of identification of released product:

a) Product conforms to original standard and certification documents **YES / NO**

b) Restrictions apply to use of this product as originally certified **YES / NO**

c) Compliance of the product has been verified by a competent person **YES/ NO /NA**

*Mark which applies to released product.*

Name of Responsible Person: ..... Signature: .....

Service Facility Record number: ..... Date: . / . / . . . . .

**B.14C.14 Assessment of Responsible Persons and Operatives**

Person verified:	Responsible Person/Operative:	
Organization:	<i>Mark which applies</i>	
ExCB Name:	Date: . . . / . . . / . . .	
Assessor:		
<b>Item</b>	<b>Qualifications and work history</b>	<b>Result</b>
(1a)	Experience in explosive atmosphere work	Number of years
(1b)	Experienced in Ex Types of Protection	"d" "i" "p" "e" "n" "t" "p" other Rotating machines <i>Mark which applies</i>
		Notes
(1c)	Working with/assessing engineering drawings	Notes
(1d)	Experience with Ex certification requirements/Standards	Notes
(1e)	What documents are required for repair, overhaul or reclamation to remain within certification? What records are required?	Notes
(1f)	Experience with Ex test requirements	Notes
<b>Item</b>	<b>Technical interview</b>	
(2a)	What is an explosive atmosphere?	
(2b)	Understanding of LEL, UEL, Gas groups, Zones 0,1, 2, 20, 21, 22, EPL	
(2c)	Explain where the Ex techniques are used (refer to 1b above for techniques claimed)	
(2d)	Explain the safety related design features for different Types of Protection (refer to 1b above for techniques claimed)	
(2e)	Explain what reclamation methods, for defective components, are appropriate for the different Types of Protection (refer to 1b above for techniques claimed)	
<b>Item</b>	<b>Assessment of skills (see 2b above)</b>	
(3a)	Use of specific mechanical test equipment (shaft/hole diameter, depth, pressure, transfer measurements, flatness, dial gauges, thread gauges, etc.)  NOTE Over-pressure test is mandatory for Ex "d"	
(3b)	Use of specific electrical test equipment (winding resistance, insulation resistance, core flux test, surface temperature, winding temperature, current, voltage)	

- (3c) Use of calibration status, history  
Understanding of measurement traceability
- (3d) Understands what to do if a piece of  
calibrated equipment is found to be faulty or  
out of calibration
- (3e) Can show how certification status is  
maintained throughout the  
repair/overhaul/reclamation process

Readline Version